

# UR

Chill Technology srl



**UR Chill Technology s.r.l.**

Sede legale e commerciale: via 4 novembre 16 - 40010 Sala Bolognese BO

Ritiro/consegna merci: Via Zucchi n. 3/d - 40068 San Lazzaro di Savena BO

Tel. +39 051/ 465079 - 6814130 Fax +39 051/ 6814823

P.IVA 02509441206 E mail info@abitenda.it Web www.abitenda.it

## SATURATOR MACHINE FOR FILLED BOTTLES **RIBAGAS** USE – SAFETY – MAINTENANCE BOOKLET

### IMPORTANT

READ THESE INSTRUCTIONS CAREFULLY BEFORE THE COMPLETE OPENING OF THE PACKAGE

KEEP THEM WITH THE MACHINE FOR FURTHER REFERENCE

#### RIBAGAS 2



Art.10701



Art.21192



Fig.1

#### RIBAGAS 4



Art.10702

### INDEX

Chap.	Description	Pag.	Chap.	Description	Pag.
	MACHINE INTRODUCING SCHEDULE	2	6	MAINTENANCE	4
	STATEMENT OF CONFORMITY	2	7	CLEANING	4
	PREARRANGED SIGNS	2		TABLE 1 drawing + legend	5
	TECHNICAL DATA	2		TABLE 2 positioning	5
1	DESCRIPTION OF THE MACHINE	2			
2	HANDLING AND UNPACKAGING	2			
3	CONNECTION TO CO2 CYLINDER	3			
4	CHOICING THE BOTTLE	3			
5	SATURATING PROCESS	3			

## INTRODUCING SCHEDULE

ART.	RIBAGAS	REGISTER N	YEAR
------	---------	------------	------

### STATEMENT OF CONFORMITY

UR Chill Tech. srl DECLARE UNDER ITS OWN RESPONSIBILITY THAT THE ABOVE MENTIONED MACHINE SUITS THE ESSENTIAL SAFETY REQUIREMENTS IN ACCORDANCE TO EEC DIRECTIVES 89/392, 91/368, 94/768 WHEN USED IN COMPLIANCE WITH THE REGULATIONS IN FORCE MENTIONED IN THIS BOOKLET

Lawful owner  
**Stefano Gollini**

### PREARRANGED SIGNS



The paragraphs preceded by this symbol, if not respected can lead to **damages or injures to people**

### NOTE

The paragraphs preceded by this symbol, if not respected can lead to **damages to the machine**

The instructions: LIFT-LOWER-CLOCKWISE-ANTICLOCKWISE-PUSH-PULL are referred to the operator staying in front of the machine in working position.

**IF THIS MACHINE IS USED IMPROPERLY OR THESE OPERATING INSTRUCTIONS ARE NOT FOLLOWED, THE MANUFACTURER DECLINES ANY AND ALL LIABILITY FOR INJURY TO PERSONS OR DAMAGE TO PROPERTY**

### TECHNICAL DATA

Art.	Name	Hourly PROD* Litres	Pressure BAR	WEIGHT Kilos	PACKING SIZE	OVERALL SIZE
10701	RIBAGAS 2	140	3	26	60x80x120	50x50x180
10702	RIBAGAS 4	280	3	50	60x60x120	50x100x180

**\*The hourly production referred to the machine is teorical: it depends on the liquid temperature, better cold at 8-10°C, and on the higher or lower gas quantity needed.**

## CHAPTER 1: DESCRIPTION OF THE MACHINE

Thank you for choicing our **SATURATOR MACHINE**



**1.1** The machine allows to mix, at ambient temperature, gas (CO2) and food liquids (water, wine, beer, fruit juices, cider).Any other use with different kind of gas is forbidden.

**1.2** The use of the machine is limited by the laws in force regarding addition of gas to food liquids.

**1.3** The machine, built in stainless steel AISI 304, works with CO2 gas (table 1) to the max pressure of 3 Atm, which you can check through the manometer (20). This pressure level is limited by the safety valve (19).



**1.4 Do not remove nor tamper the manometer and the safety valve.**



**1.5** Operator's dresses in order to avoid injury in case of bottle breakings have to include: anticrush shoes equipped with antislip soles, waterproof gloves and smock.

## CHAPTER 2: HANDLING AND UNPACKAGING OPERATIONS

**2.1** The package containing the machine can be easily transported by mean of a 2 wheels-trolley (follow the indication ALTO FRAGILE).

**2.2** Open the package and take out the machine: you will find two pieces plus the bag containing the accessories.

### NOTE

**2.3** Make sure that all parts are in perfect condition

**2.4** Set up the saturating group onto the trolley following the instructions inside.

**2.5** Waste packing: paper, cartons, bags and hooks should be placed in the correct areas or disposed for recycling.

### CHAPTER 3: CONNECTION TO THE CO2 CYLINDER (grey head)

3.1 UR srl cannot be held responsible for injuries or damages caused by improper use of the machine due to failure in respecting the laws regarding the use and handling of industrial gas. Please ask to your gas supplier the booklet explaining use and limits referred to gas

#### NOTE



**3.2 WARNING: THE CYLINDER CONTAINS HIGH COMPRESSED GAS (200 ATM). IT IS FORBIDDEN TO OPEN THE MAIN VALVE BEFORE FIXING THE CYLINDER TO A SUITABLE SUPPORT AND SETTING UP A PRESSURE REDUCER CALIBRATED AT 3 ATM.**

3.3 It is suggested to set up a suitable preheater to avoid the gas to get frozen at the exit.

3.4 Connect the RILSAN tube in dotation to the pressure reducer (already regulated at 3 atm). Put the hose clamp in.

3.5 Connect the other pipe end part with piston pin to the quick connection on the saturator (15).

3.6 Make sure that the saturator group is on a dry floor and the 2 wheels and feet perfectly adhere.

### CHAPTER 4: CHOICING THE BOTTLE



4.1 The first-class glass must be round; weight and thicknesses suitable to bear at least 4 atm.

**WARNING: do not use light or square bottles not certified. Breakings can be dangerous for the operator.**

4.2 PET plastic, PVC and other round bottles, having such a consistency to bear 3 bar pressure and the thrust of the bottle support (3).

4.3 Capacity and bottle sizes: the height of the bottle can be from 180 to 380 mm, the diameter from 50 to 140 mm and capacity from 150 to 2000 cc. By upper capacities there is no good mixing.

4.4 Thrust pressure (picture 1): in order to regulate the thrust pressure of the bottle on the head you have to put the bottle onto the bottle support being in higher position (table 2). Check if "A" size is between 45-60 mm; if not, take the guides "B" and "C" closer or push them off. In case of plastic bottles, reduce "A" size to 20 mm.

### CHAPTER 5: SATURATING PROCESS (you have to work always on the group 1 on the right)

5.1 Open by pulling the knob (25) on the casing part.

5.2 Push the lever 4 to lower the bottle support (5) till it reaches the lowest point (table 2).



5.3 Put the bottle onto the support centre. **The bottle must be filled and already height regulated (ref. 5.4).**

5.4 Leave slowly the lever 4 until the bottle is fixed in contact with the head (7).



5.5 Close the protection casing part (magnetic lock) (24).

5.6 Open the blending valve (23).

5.7 Slowly turn 180° the rotating group (the liquid comes from the bottle to the blending ball 22)

5.8 Put on the second bottle as per points 5.1 and 5.6.

5.9 Slowly turn of 180°; check the complete filling of the first bottle through the transparent spy (6).



5.10 Close the blending valve (23).

5.11 Beat the lever 4 to allow the gas exit inside the bottle-neck.

5.12 Open by pulling the knob (25) on the casing part.

5.13 Push slowly the lever 4 (to lower the support and the bottle)

5.14 Take the bottle off.

5.15 **WARNING: to obtain a good result, it is necessary to cork immediately the bottle after the saturating process.**

**CHAPTER 6: MAINTENANCE**

**6.1** Make sure that the manometer and the safety valve work correctly. If not, replace them.

**NOTE**

**6.2** Every 10 working hours: lubricate, by using lubricating oil, the clamping ball rotating part (18).

**6.3** Every 100 working hours: lubricate the bottle support spring (3) by using lubricating oil. In this case, it is necessary to unscrew anticlockwise completely and push the bottle support. Remove the spacer, the spring, then lubricate.

**6.4** Set up again all parts involved.

**CHAPTER 7: CLEANING**

**7.1** The machine has been designed and manufactured according to 89/109 EEC directives by using suitable equipment for food liquids.

**7.2** The cleaning operation should follow as mentioned in the previous point regarding food liquids: this process should be executed in a proper way, to guarantee the hygiene of the liquids being in contact with the machine.

**7.3** On stopping working, carry out a simple cleaning: fill in a bottle with specific detergents (for example: DC/4 DALCIN) according to the doses suggested by the supplier.

**7.4** Close and take off the CO2 inlet tube (14)

**7.5** Follow the same steps as the saturating process; repeat it 3-4 times, then remove the bottle filled with detergent.

**7.6** Fill in the sphere 22 with clean water; change water 2/3 times. Leave alternatively the two spheres drain in vertical position.

**7.7** Sterilization (if you have vaporization equipment).

**7.8** Open the valve (23)

**7.9** Input steam at 120° through the quick connection (15) keeping it for 20 minutes.

**7.10** Use immediately the machine.

# LEGEND

- 1) REVOLVING WHEELS
- 2) TIP
- 3) BOTTLE-SUPPORT SPRING
- 4) BOTTLE-SUPPORT LEVER
- 5) BOTTLE SUPPORT
- 6) LEVELSIGNING VIEWING GLASS
- 7) HEAD GASKET
- 8) O-RING
- 9) HEAD PART
- 10) SLIDING HEAD GROUP
- 11) HEAD CLAMPING PLUG
- 12) SLIDING SUPPORT GROUP
- 13) BRASS LOCK NUT- 14) QUICK CONNECTION WITH TUBE
- 15) QUICK CONNECTION FIXED PART
- 16) TRACTION SPRING REGULATING SCREW
- 17) CLAMPING SPRING
- 18) CLAMPING SPHERES
- 19) SAFETY VALVE
- 20) MANOMETER
- 21) NON RETURN VALVE
- 22) BLENDING BALL
- 23) BLENDING VALVE
- 24) MAGNETIC HOOK
- 25) OPENING-CASING KNOB
- 26) PROTECTION CASE PART
- 27) TROLLEY

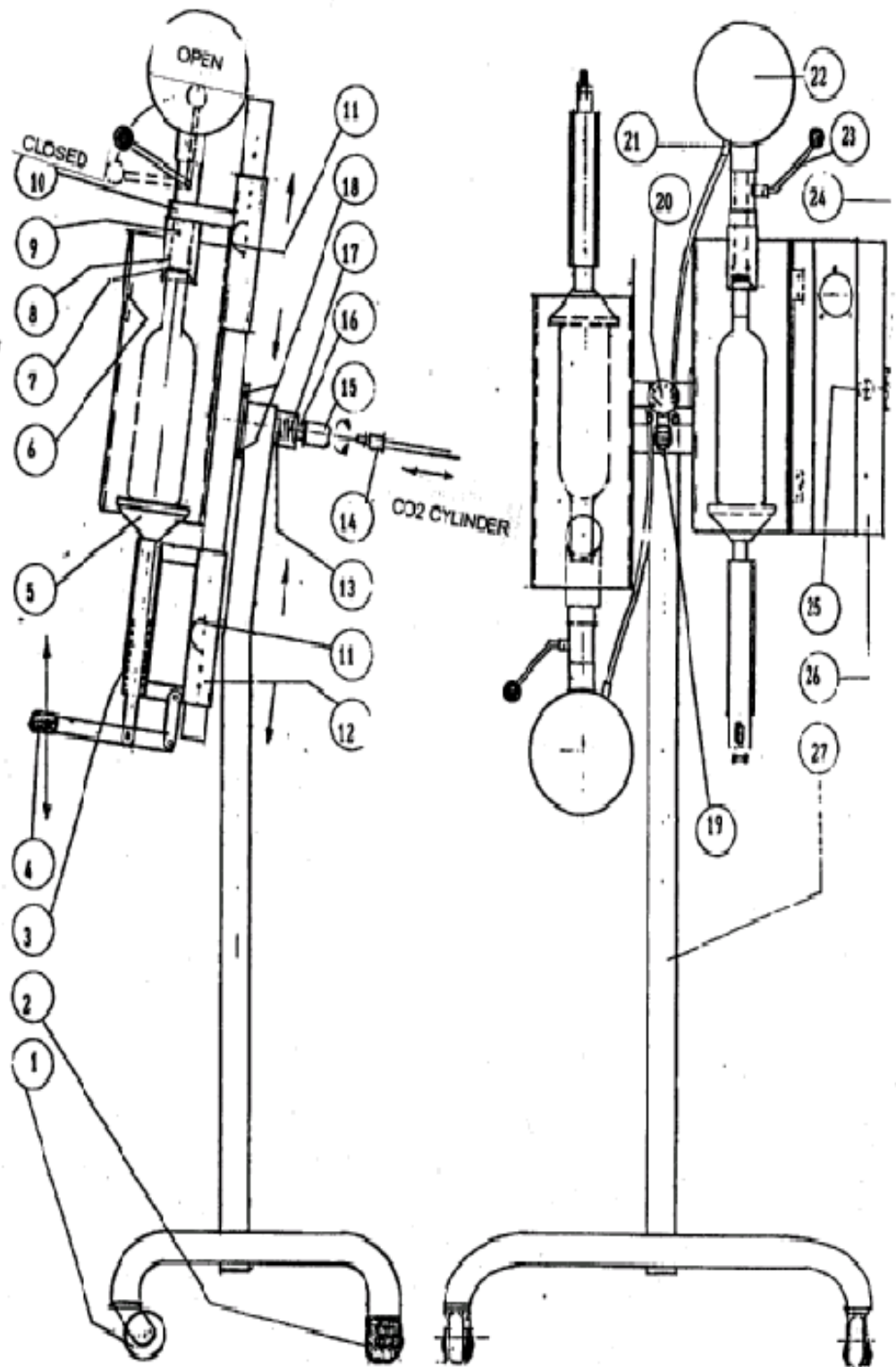

TABLE 2

